

RXL 424 PLUS

Horno para panadería



Ref. 710924

PVP



CARACTERÍSTICAS TÉCNICAS

Potencia eléctrica 3.800W

Temperatura máxima 250°C

Peso 40kg

Voltaje 230V-50Hz

Tipo conexión Schuko monofásico

Dimensiones internas (An)560x(F)415x(Al)345mm

Dimensiones externas (An)700x(F)715x(Al)540mm

Humidificador (ref. 710537)

Cambio apertura puerta

EQUIPAMIENTO-FUNCIONES

- *Alarma fin de ciclo*
- *Termostato de seguridad*
- *Temporizador 0-60 minutos*
- *Modo continuo*
- *Lampara interior*
- *Dotación: 4 parrillas*

CAPACIDAD

4 bandejas 480x340

4 bandejas GN1/1

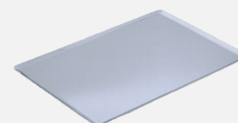

RXL 424 PLUS

Accesorios específicos



Soporte RX 48/34

Ref. 710548 | PVP 375€



(An)590x(F)580x(Al)850mm

Ruedas

Ref. 710286 | PVP 120€

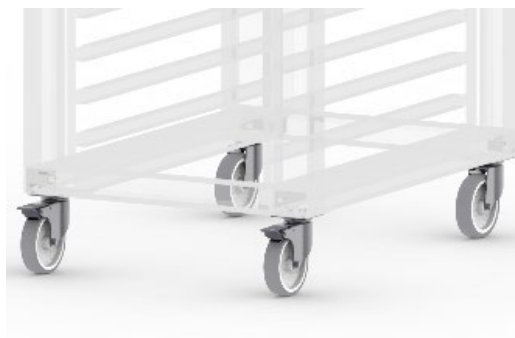

Suplemento ruedas para soportes

Kit condensador de vapores

SERIE RX

Ref. 710551 | PVP 135€

(An)170x(F)70x(Al)400mm

SERIE RX H20

Ref. 710552 | PVP 335€

(An)720x(F)85x(Al)450mm

SERIE RX DUO

Ref. 710553 | PVP 335€

(An)580x(F)120x(Al)180mm

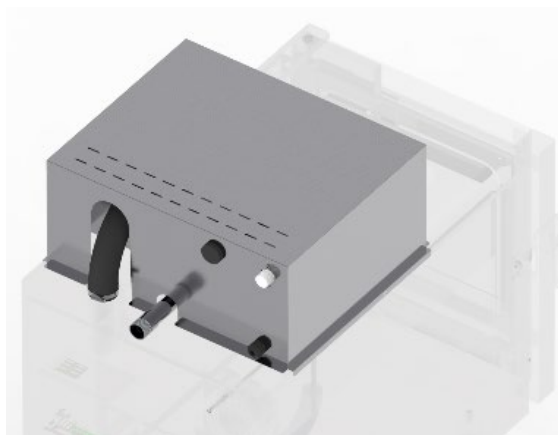

Kit superposición RX 48/34

Ref. 710555 | PVP 350€



(An)640x(F)720x(Al)40mm